

**1 TAPP**

Förzinkat stål, blåpassiverat

**2 SPÄRRHAKAR**

Rostfritt stål AISI 304

**3 FJÄDER**

Rostfritt stål AISI 302

**4 TVÅARMADE VRED**

Glasfiberförstärkt polyamidbaserad teknopolymer (PA), svart med monteringshål för fästning
Arbetstemperatur upp till 80°.

**5 TRYCKKNAPP**

Acetalbaserad teknopolymer (POM), röd.
Arbetstemperatur upp till 80°.

**6 KÄNNETECKEN OCH ANVÄNDNING**

GN 114.7 kulspärrbultar med axiell låsning används för att snabbt fixera, ansluta och säkra olika komponenter. De används i allmänhet som stödbultar när frekvent isärtagning och hopmontering krävs.

De rektangulära spärrhakarna av rostfritt stål håller låstappen i axiellt läge i hålet. De dras tillbaka med ett tryck på en knapp och när knappen släpps återför tryckfjäders dem till låst läge. Spärrhakarna är inte i linje med T-handtaget.

**7 TILLBEHÖR**

För att optimera användningen av kulspärrbultar finns följande tillgängliga:

- kulkedja GN 111 (se sidan 611);
- kabelhållare GN 111.2 (se sidan 612);
- spiralkabel GN 111.4 (se sidan 613).

**8 BRUKSANVISNING**

Genom att trycka på knappen frigörs de två spärrhakarna och tappen kan dras ut eller monteras in.

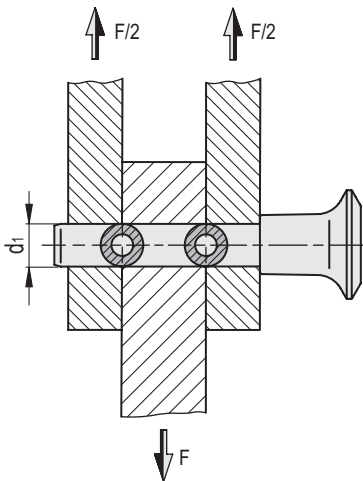
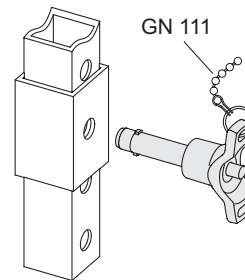
**Exempel på applikation**

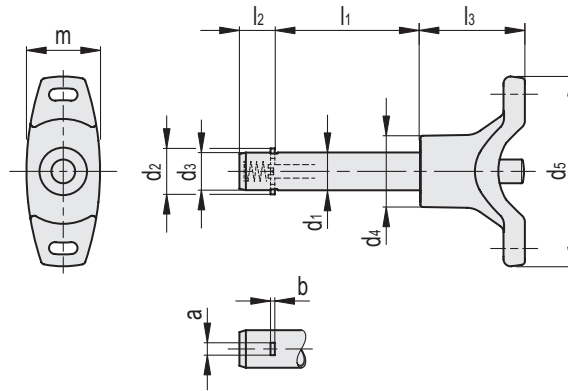

Kod	Benämning	d1 -0.1	d2	d3	d4	d5	l1 +0.4	l2	l3	a	b	m	Dubbelsidig klippkraft [kN]	⚖️
GN.80001	GN 114.7-6-10	6	7.3	5.9	15	40	10	7	22	2.3	0.5	15.5	14	14
GN.80002	GN 114.7-6-12	6	7.3	5.9	15	40	12	7	22	2.3	0.5	15.5	14	15
GN.80003	GN 114.7-6-16	6	7.3	5.9	15	40	16	7	22	2.3	0.5	15.5	14	16
GN.80004	GN 114.7-6-20	6	7.3	5.9	15	40	20	7	22	2.3	0.5	15.5	14	17
GN.80005	GN 114.7-6-25	6	7.3	5.9	15	40	25	7	22	2.3	0.5	15.5	14	18
GN.80006	GN 114.7-6-30	6	7.3	5.9	15	40	30	7	22	2.3	0.5	15.5	14	19
GN.80007	GN 114.7-6-35	6	7.3	5.9	15	40	35	7	22	2.3	0.5	15.5	14	20
GN.80008	GN 114.7-6-40	6	7.3	5.9	15	40	40	7	22	2.3	0.5	15.5	14	21
GN.80009	GN 114.7-6-45	6	7.3	5.9	15	40	45	7	22	2.3	0.5	15.5	14	22
GN.80010	GN 114.7-6-50	6	7.3	5.9	15	40	50	7	22	2.3	0.5	15.5	14	23
GN.80011	GN 114.7-6-60	6	7.3	5.9	15	40	60	7	22	2.3	0.5	15.5	14	24
GN.80012	GN 114.7-6-70	6	7.3	5.9	15	40	70	7	22	2.3	0.5	15.5	14	25
GN.80013	GN 114.7-6-80	6	7.3	5.9	15	40	80	7	22	2.3	0.5	15.5	14	26
GN.80021	GN 114.7-8-10	8	9.8	7.9	15	40	10	8.4	22	2.8	0.6	15.5	28	17
GN.80022	GN 114.7-8-16	8	9.8	7.9	15	40	16	8.4	22	2.8	0.6	15.5	28	19
GN.80023	GN 114.7-8-20	8	9.8	7.9	15	40	20	8.4	22	2.8	0.6	15.5	28	20
GN.80024	GN 114.7-8-25	8	9.8	7.9	15	40	25	8.4	22	2.8	0.6	15.5	28	22
GN.80025	GN 114.7-8-30	8	9.8	7.9	15	40	30	8.4	22	2.8	0.6	15.5	28	24
GN.80026	GN 114.7-8-35	8	9.8	7.9	15	40	35	8.4	22	2.8	0.6	15.5	28	25
GN.80027	GN 114.7-8-40	8	9.8	7.9	15	40	40	8.4	22	2.8	0.6	15.5	28	27
GN.80028	GN 114.7-8-45	8	9.8	7.9	15	40	45	8.4	22	2.8	0.6	15.5	28	29
GN.80029	GN 114.7-8-50	8	9.8	7.9	15	40	50	8.4	22	2.8	0.6	15.5	28	30
GN.80030	GN 114.7-8-60	8	9.8	7.9	15	40	60	8.4	22	2.8	0.6	15.5	28	34
GN.80031	GN 114.7-8-70	8	9.8	7.9	15	40	70	8.4	22	2.8	0.6	15.5	28	37
GN.80032	GN 114.7-8-80	8	9.8	7.9	15	40	80	8.4	22	2.8	0.6	15.5	28	40
GN.80033	GN 114.7-8-90	8	9.8	7.9	15	40	90	8.4	22	2.8	0.6	15.5	28	44
GN.80034	GN 114.7-8-100	8	9.8	7.9	15	40	100	8.4	22	2.8	0.6	15.5	28	47
GN.80041	GN 114.7-10-15	10	11.7	9.9	18	48	15	9.8	27.5	3.3	1	20	38	31
GN.80042	GN 114.7-10-20	10	11.7	9.9	18	48	20	9.8	27.5	3.3	1	20	38	33
GN.80043	GN 114.7-10-25	10	11.7	9.9	18	48	25	9.8	27.5	3.3	1	20	38	36
GN.80044	GN 114.7-10-30	10	11.7	9.9	18	48	30	9.8	27.5	3.3	1	20	38	38
GN.80045	GN 114.7-10-35	10	11.7	9.9	18	48	35	9.8	27.5	3.3	1	20	38	40
GN.80046	GN 114.7-10-40	10	11.7	9.9	18	48	40	9.8	27.5	3.3	1	20	38	43
GN.80047	GN 114.7-10-45	10	11.7	9.9	18	48	45	9.8	27.5	3.3	1	20	38	45
GN.80048	GN 114.7-10-50	10	11.7	9.9	18	48	50	9.8	27.5	3.3	1	20	38	47
GN.80049	GN 114.7-10-60	10	11.7	9.9	18	48	60	9.8	27.5	3.3	1	20	38	52
GN.80050	GN 114.7-10-70	10	11.7	9.9	18	48	70	9.8	27.5	3.3	1	20	38	56
GN.80051	GN 114.7-10-80	10	11.7	9.9	18	48	80	9.8	27.5	3.3	1	20	38	61
GN.80052	GN 114.7-10-90	10	11.7	9.9	18	48	90	9.8	27.5	3.3	1	20	38	65
GN.80053	GN 114.7-10-100	10	11.7	9.9	18	48	100	9.8	27.5	3.3	1	20	38	70
GN.80054	GN 114.7-10-110	10	11.7	9.9	18	48	110	9.8	27.5	3.3	1	20	38	75
GN.80055	GN 114.7-10-120	10	11.7	9.9	18	48	120	9.8	27.5	3.3	1	20	38	79



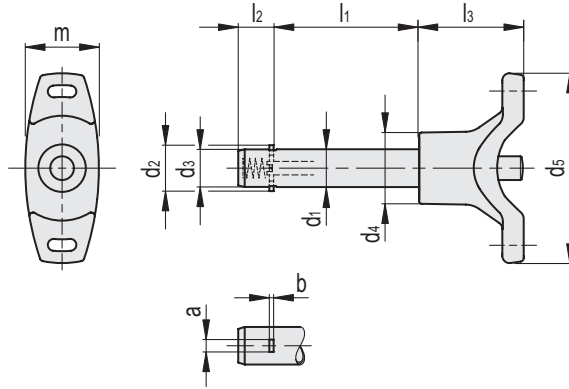

Kod	Benämning	d1 -0.1	d2	d3	d4	d5	l1 +0.4	l2	l3	a	b	m	Dubbelsidig klippkraft [kN]	⚖
GN.80061	GN 114.7-12-20	12	13.7	11.9	18	48	20	11.3	27.5	3.8	1	20	61	41
GN.80062	GN 114.7-12-25	12	13.7	11.9	18	48	25	11.3	27.5	3.8	1	20	61	45
GN.80063	GN 114.7-12-30	12	13.7	11.9	18	48	30	11.3	27.5	3.8	1	20	61	48
GN.80064	GN 114.7-12-35	12	13.7	11.9	18	48	35	11.3	27.5	3.8	1	20	61	52
GN.80065	GN 114.7-12-40	12	13.7	11.9	18	48	40	11.3	27.5	3.8	1	20	61	56
GN.80066	GN 114.7-12-45	12	13.7	11.9	18	48	45	11.3	27.5	3.8	1	20	61	59
GN.80067	GN 114.7-12-50	12	13.7	11.9	18	48	50	11.3	27.5	3.8	1	20	61	63
GN.80068	GN 114.7-12-60	12	13.7	11.9	18	48	60	11.3	27.5	3.8	1	20	61	70
GN.80069	GN 114.7-12-70	12	13.7	11.9	18	48	70	11.3	27.5	3.8	1	20	61	78
GN.80070	GN 114.7-12-80	12	13.7	11.9	18	48	80	11.3	27.5	3.8	1	20	61	85
GN.80071	GN 114.7-12-90	12	13.7	11.9	18	48	90	11.3	27.5	3.8	1	20	61	92
GN.80072	GN 114.7-12-100	12	13.7	11.9	18	48	100	11.3	27.5	3.8	1	20	61	100
GN.80073	GN 114.7-12-110	12	13.7	11.9	18	48	110	11.3	27.5	3.8	1	20	61	107
GN.80074	GN 114.7-12-120	12	13.7	11.9	18	48	120	11.3	27.5	3.8	1	20	61	115
GN.80081	GN 114.7-16-30	16	18.7	15.9	22	58	30	14.2	34.5	4.8	1.2	27	113	95
GN.80082	GN 114.7-16-35	16	18.7	15.9	22	58	35	14.2	34.5	4.8	1.2	27	113	101
GN.80083	GN 114.7-16-40	16	18.7	15.9	22	58	40	14.2	34.5	4.8	1.2	27	113	108
GN.80084	GN 114.7-16-45	16	18.7	15.9	22	58	45	14.2	34.5	4.8	1.2	27	113	115
GN.80085	GN 114.7-16-50	16	18.7	15.9	22	58	50	14.2	34.5	4.8	1.2	27	113	122
GN.80086	GN 114.7-16-60	16	18.7	15.9	22	58	60	14.2	34.5	4.8	1.2	27	113	135
GN.80087	GN 114.7-16-70	16	18.7	15.9	22	58	70	14.2	34.5	4.8	1.2	27	113	149
GN.80088	GN 114.7-16-80	16	18.7	15.9	22	58	80	14.2	34.5	4.8	1.2	27	113	162
GN.80089	GN 114.7-16-90	16	18.7	15.9	22	58	90	14.2	34.5	4.8	1.2	27	113	176
GN.80090	GN 114.7-16-100	16	18.7	15.9	22	58	100	14.2	34.5	4.8	1.2	27	113	190
GN.80091	GN 114.7-16-110	16	18.7	15.9	22	58	110	14.2	34.5	4.8	1.2	27	113	203
GN.80092	GN 114.7-16-120	16	18.7	15.9	22	58	120	14.2	34.5	4.8	1.2	27	113	217
GN.80093	GN 114.7-16-130	16	18.7	15.9	22	58	130	14.2	34.5	4.8	1.2	27	113	230
GN.80094	GN 114.7-16-140	16	18.7	15.9	22	58	140	14.2	34.5	4.8	1.2	27	113	244
GN.80095	GN 114.7-16-150	16	18.7	15.9	22	58	150	14.2	34.5	4.8	1.2	27	113	257
GN.80101	GN 114.7-20-30	20	22.7	19.8	25	58	30	14.8	34.5	4.8	1.2	27	187	133
GN.80102	GN 114.7-20-35	20	22.7	19.8	25	58	35	14.8	34.5	4.8	1.2	27	187	145
GN.80103	GN 114.7-20-40	20	22.7	19.8	25	58	40	14.8	34.5	4.8	1.2	27	187	156
GN.80104	GN 114.7-20-45	20	22.7	19.8	25	58	45	14.8	34.5	4.8	1.2	27	187	167
GN.80105	GN 114.7-20-50	20	22.7	19.8	25	58	50	14.8	34.5	4.8	1.2	27	187	178
GN.80106	GN 114.7-20-60	20	22.7	19.8	25	58	60	14.8	34.5	4.8	1.2	27	187	201
GN.80107	GN 114.7-20-70	20	22.7	19.8	25	58	70	14.8	34.5	4.8	1.2	27	187	223
GN.80108	GN 114.7-20-80	20	22.7	19.8	25	58	80	14.8	34.5	4.8	1.2	27	187	245
GN.80109	GN 114.7-20-90	20	22.7	19.8	25	58	90	14.8	34.5	4.8	1.2	27	187	268
GN.80110	GN 114.7-20-100	20	22.7	19.8	25	58	100	14.8	34.5	4.8	1.2	27	187	290
GN.80111	GN 114.7-20-110	20	22.7	19.8	25	58	110	14.8	34.5	4.8	1.2	27	187	312
GN.80112	GN 114.7-20-120	20	22.7	19.8	25	58	120	14.8	34.5	4.8	1.2	27	187	335
GN.80113	GN 114.7-20-130	20	22.7	19.8	25	58	130	14.8	34.5	4.8	1.2	27	187	357
GN.80114	GN 114.7-20-140	20	22.7	19.8	25	58	140	14.8	34.5	4.8	1.2	27	187	380
GN.80115	GN 114.7-20-150	20	22.7	19.8	25	58	150	14.8	34.5	4.8	1.2	27	187	402